

## 48 inch Induction Range, 6 Heating Zones and Cast Iron Griddle, Electric Self-Clean Oven Professional Series

\$ 13,999



### PRO486IGFEPCAT

The new Bertazzoni ranges are superb cooking appliances designed, engineered and made in Italy. All Bertazzoni appliances integrate seamlessly into style-harmonized suites for a true, high-performing kitchen.

This all-new induction range has 6 high-power heating zones with maximum power output of 3700W. The right-side heating zones can be bridged to create a larger cooking area. Each induction area is controlled with knobs and has a convenient read-out interface on the glass worktop. A large, removable cast-iron griddle is included.

The 4.6 cubic feet self-cleaning oven is the largest in its class, with dual convection fan for balanced airflow and even temperature baking and roasting on 7 shelf levels. The elegant digital temperature gauge monitors the actual temperature in the oven and has integrated controls in the bezel for the food temperature probe. The extra wide electric broiler with optional convection is ideal for grilling and searing at high heat. The 2.4 cubic feet auxiliary oven is perfect for smaller dishes and for warming. Both ovens include convenient features such as smooth telescopic glides for the oven shelves and soft-close doors. The edge-to-edge interior oven glass door maximizes interior volume and can be wiped clean without effort.

This range comes with a dedicated air-frying mode for healthier cooking, to be used with the included stainless steel mesh basket.

All Bertazzoni appliances are covered by a 2-year warranty.

[Guarda online](#)



# Specifications

## Features

### Worktop

Size	48 in
Cooking zones	6
Number of induction zones	6
Worktop type	induction
Worktop design	stainless steel squared
Worktop controls	knobs
Knobs	metal coated
Backguard	yes
Cast iron griddle	yes

### Cooking zones

Induction 2 bridge zones	yes
Induction front left	(Ø 8 in 9/32) 2300 W - 3700 W
Induction back left	(Ø 8 in 9/32) 2300 W - 3700 W
Induction center	(Ø 8 in 9/32) 2300 W - 3700 W
Induction back center	(Ø 10 in 1/4) 2600 W - 3700 W
Induction front right	Bridge 2100 W - 3700 W
Induction back right	Bridge 2100 W - 3700 W

### Oven cavity

Oven configuration	double
Oven fuel	electric
Oven type	self-clean
Oven volume	4.6 ft <sup>3</sup>
Oven convection system	dual diagonal with heating element
Main oven type	electric pyrolytic
Main oven broiler type	electric
Main oven functions	air fry / bake / broiler / convection / convection bake / convection broiler / defrosting / dehydrate / pizza / proofing / pyrolytic self clean / warming
Auxiliary oven type	electric conventional

Auxiliary oven broiler type	electric
Auxiliary oven functions	bake / bottom bake / broiler / proofing / upper bake
Auxiliary oven volume	2.4 ft <sup>3</sup>
Inner oven door	triple
Removable inner glass	yes
Oven levels	7
Food probe	yes
Door hinges	soft-close
Air fryer	yes
Sliding shelves	2 sets of telescopic glides
Wire-shelves	2 each cavity
Tray	1 baking tray w/grill trivet + 1 air fry basket
Grill trivet for tray	yes
Oven lights	double lateral

**Bottom**

Legs	stainless steel
------	-----------------

**Technical specifications**

Absorbed current (A)	50 A with dedicated circuit
Electrical supply	120/240V - 60Hz - 15 100W 120/208V - 60Hz - 18 500W

**Dimensions**

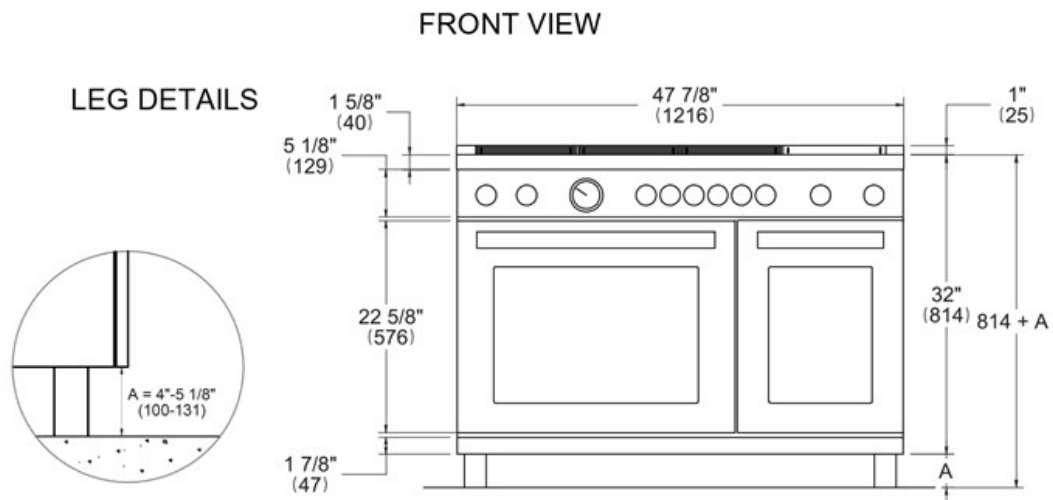

---